

PRODUCT OVERVIEW

SustainAir 650



Axonometry view



Front view

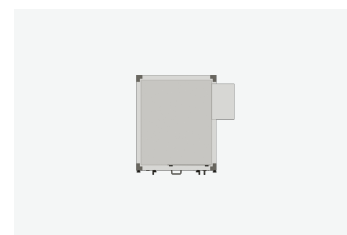

Top view

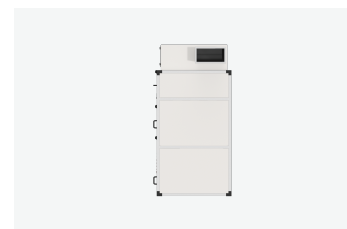

Side view

GREENTECH RECIRCULATION

SIZE (W x D x H)

650 x 1000 x 2300 mm

MATERIAL & FINISHING

0.8 mm stainless steel

FEATURES

- Removable top plenum box
- Cassate filter & Bag filter
- Carbon filter & V module hepa filter
- Fan discharge grill
- Control panel
- Voltage: 380
- Power: 2.2 kW
- Revolution: 1500 D/D
- Also available in horizontal mode

DUCTLESS CONVENIENCE

Our innovative recirculation units eliminate the need for external ducting, offering easy installation and flexibility for any location, including challenging spaces.

VERSATILE FOR ALL COMMERCIAL ENVIRONMENTS

These units are perfect over electrical appliances, ensuring top-notch ventilation in airports, stadiums, and more.

ADVANCED MULTI-STAGE FILTRATION

Our units feature a sophisticated filtration system, removing grease, smoke, and odors, and enhancing fire safety, efficiency, and sustainability.

CUSTOMIZABLE FOR EVERY KITCHEN DESIGN

Available in various sizes, our units can be tailored to any kitchen layout, including bespoke sizes for island canopies, ensuring a perfect fit for your specific needs.

POWERFUL AND EFFICIENT AIR FILTRATION

Equipped with high-performance fan motors, our units provide exceptional air filtration, suitable for the demands of any busy commercial kitchen. Elevate your kitchen with our efficient, adaptable, and user-friendly recirculation units.

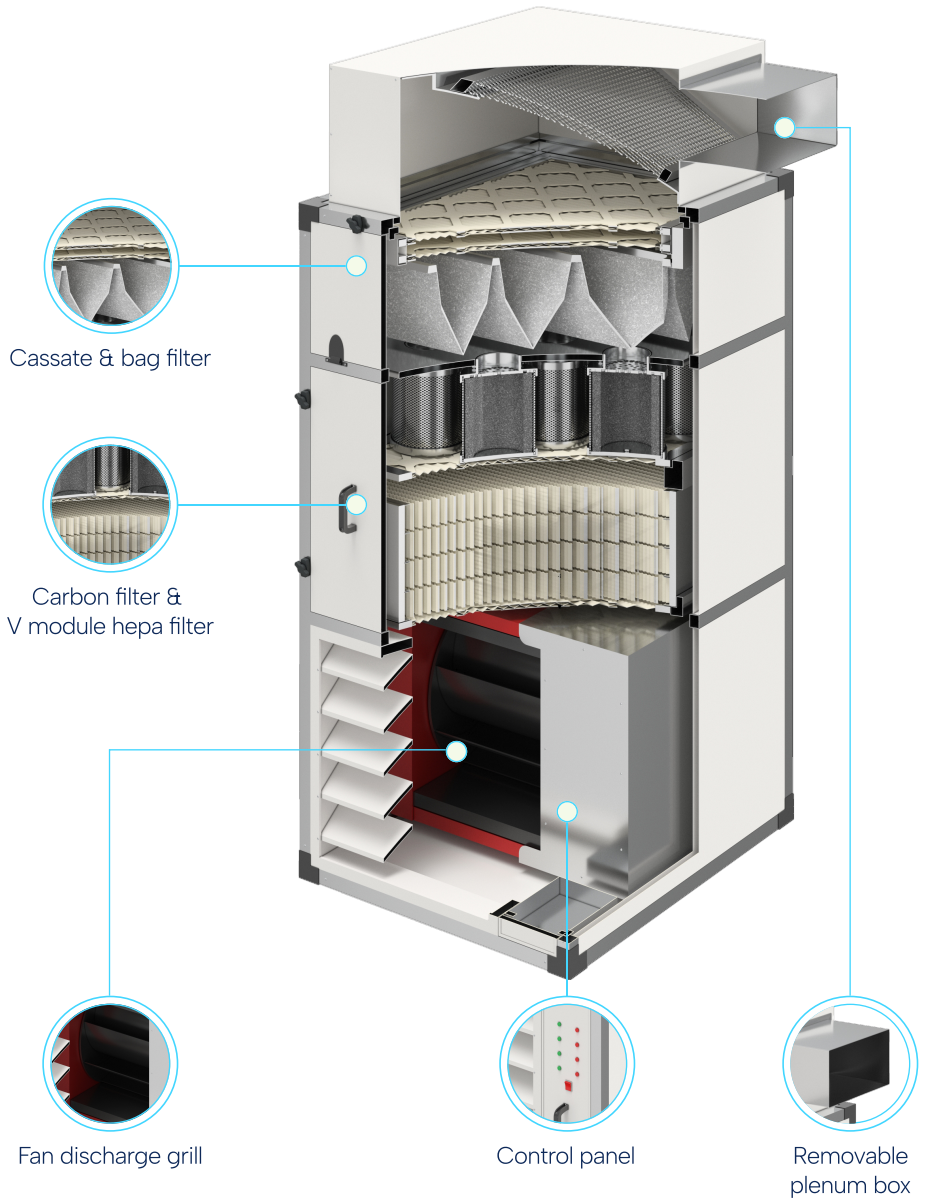

DIMENSION

TOP VIEW

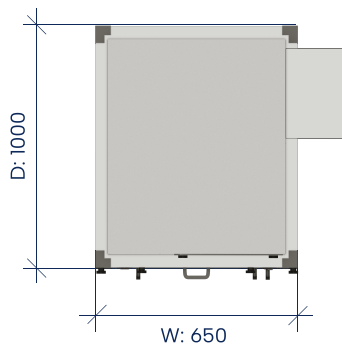

FRONT VIEW

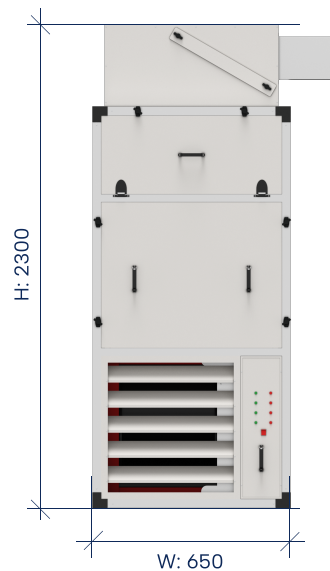

SIDE VIEW

