



innovair

Product Booklet

/ 2024



About Us

Mattaş Endüstriyel Mutfak Sanayii A.Ş., established in 1985, has become a leading force in the industrial kitchen sector known for innovation and quality. In 35 years, it has transformed from a small enterprise into a symbol of excellence, prioritizing creativity, customer satisfaction, and quality. Their impressive 7000 m² facility, staffed by 45 skilled managers and engineers, has delivered over 4000 comprehensive kitchen projects, demonstrating their expertise.

At the core of Mattaş' expansion is their commitment to adopting modern technology in manufacturing, consistently diversifying their product offerings, and placing customer fulfillment as a top priority. Their relentless pursuit of innovation, facilitated by CNC-enabled machinery in both production and design, keeps them ahead in the industrial kitchen sector.



List of Contents

Storage	1
Hoods	5
Sinks	9
Faucets	12
Doors	15
Grease Trap	17

innovair

Storage

SecureGuard 4-Doors Staff Locker



4-DOORS LOCKER

SIZE (W x D x H)	305 x 305 x 1778 mm
MATERIAL & FINISHING	Electrostatic matte black or semi-matte black painted carbon steel sheet.
FEATURES	<ul style="list-style-type: none"> Name holder on each door Padlock slot on each door Corner vent perforations on each door Full-length door stiffener

FlexSecure XXL Mobile Storage Cage



4-STOREY MOBILE STORAGE CAGE

SIZE (W x D x H)	1200 x 800 x 900 mm
LOAD CAPACITY	<ul style="list-style-type: none"> 500 kg 100 kg per shelf
MATERIAL & FINISHING	Carbon Steel with bright zinc plate finish
FEATURES	<ul style="list-style-type: none"> 2x fixed castors & 2x swivel castors 12x detachable hinges

HeatWave Stainless Steel Food Warmer System



SHELF HEATING SYSTEM

SIZE (W x D x H)	1000 x 300 x 315 mm
MATERIAL & FINISHING	AISI-430 Stainless Steel
FEATURES	<ul style="list-style-type: none"> Thermostat Sensor 250W Heater

HeatWave Stainless Steel Food Warmer Shelf



DESPATCH HOLDING SHELF

SIZE (W x D x H)	1500 x 300 x 1575 mm*
MATERIAL & FINISHING	AISI-430 Stainless Steel
FEATURES	<ul style="list-style-type: none"> Easy clean stainless steel Slotted wall brackets Individually thermostatic controlled shelves* Electric power 1,5 kW**

FlexSecure Mobile Storage Cage



MOBILE STORAGE CAGE

SIZE (W x D x H)	720 x 610 x 2000 mm
LOAD CAPACITY	500 kg
MATERIAL & FINISHING	Galvanized Coated Wire
FEATURES	<ul style="list-style-type: none"> Outer tube diameter 21 mm Shelves are optional 2x fixed castors & 2x swivel castors Single door 1x locking mechanism Wire diameter 4.5 mm

HealthGuard Demountable Antibacterial Wire Shelf



DEMOUNTABLE ANTIBACTERIAL WIRE SHELF

SIZE (W x D x H)	460 x 910 x 1830 mm
LOAD CAPACITY	320 kg
MATERIAL & FINISHING	Grey Epoxy Coated Wire
FEATURES	<ul style="list-style-type: none"> Includes 4x shelves and 4x 63" posts Suitable for dry, humid, wet and walk-in cooler use

HealthGuard Antibacterial Fixed Stainless Steel Shelf



FIXED STORAGE RACK WITH CUSTOMIZABLE SIZE & SHELF QUANTITY

SIZE (W x D x H)	1400 x 580 x 1600 mm*
LOAD CAPACITY	500 kg
MATERIAL & FINISHING	0.8 mm Stainless Steel
FEATURES	<ul style="list-style-type: none"> Customizable size and shelf quantity Shelves are available in flat and perforated surfaces Fixed shelf height gap Height-adjustable plastic covered ball joint feet

HealthGuard Antibacterial Adjustable Stainless Steel Shelf



ADJUSTABLE STORAGE RACK WITH CUSTOMIZABLE SIZE & SHELF QUANTITY

SIZE (W x D x H)	1400 x 580 x 1600 mm*
LOAD CAPACITY	500 kg
MATERIAL & FINISHING	0.8 mm Stainless Steel
FEATURES	<ul style="list-style-type: none"> Customizable size and shelf quantity Shelves are available in flat and perforated surfaces Fixed shelf height gap Height-adjustable plastic covered ball joint feet

innovair

Exhaust System

ExtractPro 2000 High Extract Canopy



HIGH EXTRACT CANOPY

SIZE (W x D x H)	2000 x 1200 x 450 mm
MATERIAL & FINISHING	0.8 mm stainless steel, fully welded and polished construction
FEATURES	Grease collection tray First rated LED spot light 500Lux © work level Canopy weight: 77kg Includes 4 Baffle Filters

ExtractPro 2500 High Extract Canopy



EXTRACTPRO 2500 HIGH EXTRACT CANOPY

SIZE (W x D x H)	2500 x 1200 x 450 mm
MATERIAL & FINISHING	0.8 mm stainless steel, fully welded and polished construction
FEATURES	Grease collection tray First rated LED spot light 500Lux © work level Canopy weight: 85kg Includes 5 Baffle Filters

ExtractMax 2000 Capture System



EXTRACT ONLY CAPTURE JET

SIZE (W x D x H)	2000 x 1200 x 450 mm
MATERIAL & FINISHING	0.8 mm stainless steel, fully welded and polished construction
FEATURES	Grease collection tray First rated LED spot light 500Lux © work level Canopy weight: 85kg Includes 5 Baffle Filters

ExtractMax 2500 Capture System



EXTRACT ONLY CAPTURE JET

SIZE (W x D x H)	2500 x 1200 x 450 mm
MATERIAL & FINISHING	0.8 mm stainless steel, fully welded and polished construction
FEATURES	<ul style="list-style-type: none"> Fans for negative pressure flow Grease collection tray First rated LED spot light 500Lux © work level Canopy weight: 100kg Includes 5 Baffle Filters

DualFlow 2000 Extract Capture Solution



EXTRACT SUPPLY & CAPTURE JET

SIZE (W x D x H)	2000 x 1200 x 450 mm
MATERIAL & FINISHING	0.8 mm stainless steel, fully welded and polished construction
FEATURES	<ul style="list-style-type: none"> Grease collection tray First rated LED spot light 500Lux © work level Canopy weight: 87kg Includes 4 Baffle Filters

DualFlow 2500 Extract Capture Solution



EXTRACT SUPPLY & CAPTURE JET

SIZE (W x D x H)	2500 x 1200 x 450 mm
MATERIAL & FINISHING	0.8 mm stainless steel, fully welded and polished construction
FEATURES	<ul style="list-style-type: none"> Grease collection tray First rated LED spot light 500Lux © work level Canopy weight: 98kg Includes 5 Baffle Filters

TaperFlow 2000 Extract Solution



HIGH EXTRACT CANOPY

SIZE (W x D x H)	2000 x 1200 x 450 mm
MATERIAL & FINISHING	0.8 mm stainless steel, fully welded and polished construction
FEATURES	<ul style="list-style-type: none"> Grease collection tray First rated LED spot light 500Lux © work level Canopy weight: 68kg Includes 4 Baffle Filters

TaperFlow 2500 Extract Solution



HIGH EXTRACT CANOPY

SIZE (W x D x H)	2500 x 1200 x 450-150 mm
MATERIAL & FINISHING	0.8 mm stainless steel, fully welded and polished construction
FEATURES	<ul style="list-style-type: none"> Grease collection tray First rated LED spot light 500Lux © work level Canopy weight: 75kg Includes 5 Baffle Filters

SustainAir 650



GREENTECH RECIRCULATION

SIZE (W x D x H)	650 x 1000 x 2300 mm
MATERIAL & FINISHING	0.8 mm stainless steel
FEATURES	<ul style="list-style-type: none"> Removable top plenum box Cassate filter & Bag filter Carbon filter & V module hepa filter Fan discharge grill Control panel Voltage: 380 Power: 2.2 kW Revolution: 1500 D/D Also available in horizontal mode

innovair

Sink

AquaFlow Single-Bowl Stainless Steel Sink



SINGLE-BOWL SINK

SIZE (W x D x H)	600 x 600 x 900 mm
SINK SIZE (W x D x H)	400 x 400 x 250 mm (Inner Bowl)
MATERIAL & FINISHING	AISI-304 (18/8-10) Stainless Steel
FEATURES	<ul style="list-style-type: none"> Adjustable ball joint feet Contoured top table designed to prevent water overflow Stainless steel sheet profiles are strategically reinforced at appropriate locations based on the bench lengths Upon request, a built-in tap hole can be incorporated into the top table The top table comes with a 60 mm back, and the back height can be customized to the preferred size or omitted altogether

HygieneMax Handwash Sink



SINGLE-BOWL SINK

SIZE (W x D x H)	600 x 600 x 900 mm
SINK SIZE (W x D x H)	400 x 400 x 250 mm (Inner Bowl)
MATERIAL & FINISHING	AISI-304 (18/8-10) Stainless Steel
FEATURES	<ul style="list-style-type: none"> Adjustable ball joint feet Contoured top table designed to prevent water overflow Stainless steel sheet profiles are strategically reinforced at appropriate locations based on the bench lengths Upon request, a built-in tap hole can be incorporated into the top table The top table comes with a 60 mm back, and the back height can be customized to the preferred size or omitted altogether

HygieneMax Knee Operated Handwash Sink



SINGLE-BOWL SINK

SIZE (W x D x H)	390 x 360 x 200 mm
SINK SIZE (W x D x H)	300 x 350 mm
MATERIAL & FINISHING	0.8 mm stainless steel
FEATURES	<ul style="list-style-type: none"> Includes tap neck, timed tap and 2 water connection hoses Wall fixing points

HygieneMax Elbow Operated Handwash Sink



SINGLE-BOWL SINK

SIZE (W x D x H)	390 x 360 x 200 mm
SINK SIZE (W x D x H)	300 x 350 mm
MATERIAL & FINISHING	0.8 mm stainless steel
FEATURES	Elbow controlled tap Wall fixing points Includes tap and 2 water connection hoses

AquaFlow Double-Bowl Stainless Steel Sink



DOUBLE-BOWL STAINLESS STEEL SINK

SIZE (W x D x H)	1000 x 600 x 900 mm
SINK SIZE (W x D x H)	400 x 400 x 250 mm (Inner Bowl)
MATERIAL & FINISHING	AISI-304 (18/8-10) Stainless Steel
FEATURES	Adjustable ball joint feet Contoured top table designed to prevent water overflow Stainless steel sheet profiles are strategically reinforced at appropriate locations based on the bench lengths Upon request, a built-in tap hole can be incorporated into the top table The top table comes with a 60 mm back, and the back height can be customized to the preferred size or omitted altogether

HygieneMax Knee-Operated Double-Bowl Sink



KNEE-OPERATED SINK

SIZE (W x D x H)	1000 x 600 x 850 mm
SINK SIZE (W x D x H)	400 x 400 mm (Inner Bowl) 405 x 405 mm (Outer Sink)
MATERIAL & FINISHING	AISI-304 Stainless Steel
FEATURES	Knee-Operated Hand Tap included Knee-Operated Hand Tap can be positioned on either the left or right side "Push" indicator on the frontal part of the sink

innovair

Faucets

Manual Mixed Tap



DOUBLE WATER INLET ROTATABLE FAUCET

SIZE (D x H)	220 x 125 mm
MATERIAL & FINISHING	Stainless steel, chromium color
FEATURES	<ul style="list-style-type: none"> Bench type Double water inlet Ideal use 3.0 bar Rotatable

Sprayer Mixer



SPRAYER MIXER

SIZE (W x D x H)	150 x 440 x 1300 mm
MATERIAL & FINISHING	Stainless Steel & Brass
FEATURES	<ul style="list-style-type: none"> Ceramic cartridge with temperature and flow limiter 3/8 steel braided, copper ring connection flex Movable rotating pipe Hand shower with movable control

Sprayer Mixer with Tap (Counter-mounted)



SPRAYER MIXER

SIZE (W x D x H)	150 x 440 x 1300 mm
MATERIAL & FINISHING	Stainless Steel & Brass
FEATURES	<ul style="list-style-type: none"> Special aerator (foamy flow, lime breaker) Rotating pipe Flexible spiral spring spout pipe Spray flow with manual on/off Diverter unit Hot and cold water flex hose connection Ideal working pressure 3-4 bar

Sprayer Mixer with Tap (Wall-mounted)



SPRAYER MIXER

SIZE (W x D x H)	150 x 440 x 1600 mm
MATERIAL & FINISHING	Stainless Steel & Brass
FEATURES	<ul style="list-style-type: none"> Special aerator (foamy flow, lime breaker) Rotating pipe Flexible spiral spring spout pipe Spray flow with manual on/off Diverter unit Hot and cold water flex hose connection Ideal working pressure 3-4 bar

Sprayer Mixer without Tap (Counter-mounted)



SPRAYER MIXER

SIZE (W x D x H)	150 x 440 x 1600 mm
MATERIAL & FINISHING	Stainless Steel & Brass
FEATURES	<ul style="list-style-type: none"> Special aerator (foamy flow, lime breaker) Rotating pipe Flexible spiral spring spout pipe Spray flow with manual on/off Diverter unit Hot and cold water flex hose connection Ideal working pressure 3-4 bar

Sprayer Mixer without Tap (Wall-mounted)



SPRAYER MIXER

SIZE (W x D x H)	150 x 440 x 1700 mm
MATERIAL & FINISHING	Stainless Steel & Brass
FEATURES	<ul style="list-style-type: none"> Special aerator (foamy flow, lime breaker) Rotating pipe Flexible spiral spring spout pipe Spray flow with manual on/off Diverter unit Hot and cold water flex hose connection Ideal working pressure 3-4 bar

innovair

Doors

GalvaGuard Galvanized Steel Doors
(with window)



1 MM GALVANIZED ELECTROSTATIC PAINTED STEEL

SIZE (W x D x H)	1200 x 2100 mm (customizable)
MATERIAL & FINISHING	0.8 mm Stainless Steel
FEATURES	<ul style="list-style-type: none"> 40x40mm steel tube skeleton Fire rated Tempered glass 3 hinges support system Key lock door Customizable color (black, blue, red, green)

GalvaGuard Galvanized Steel Doors
(without window)



1 MM GALVANIZED ELECTROSTATIC PAINTED STEEL

SIZE (W x D x H)	1325 x 2187.5 mm
MATERIAL & FINISHING	0.8 mm Stainless Steel
FEATURES	<ul style="list-style-type: none"> Key lock door Door jamb 3 hinges support system Includes tap neck, timed tap and 2 water connection hoses

innovair

Grease Trap

Mobile GreaseGuard

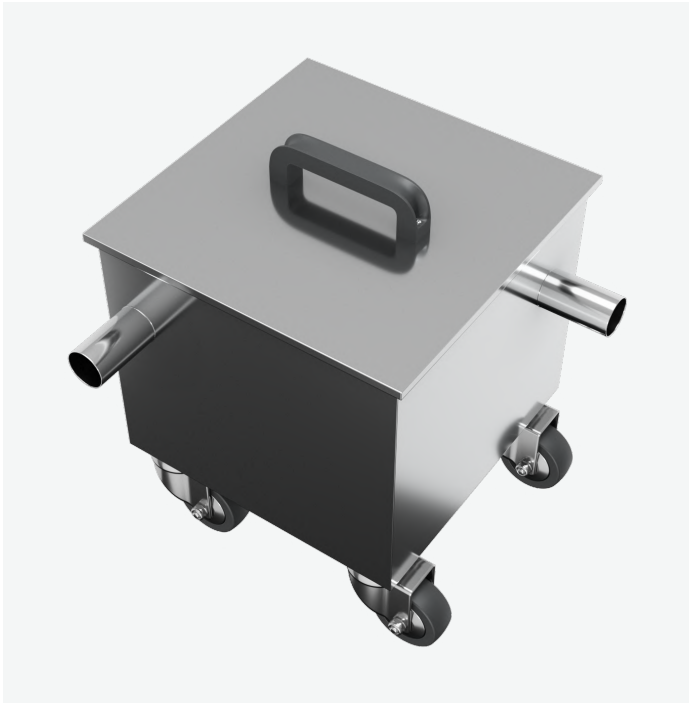

MOBILE GREASE TRAP WITH COVER

SIZE (W x D x H) 400 x 400 x 350 mm

MATERIAL & FINISHING Custom made AISI-304 stainless steel

- FEATURES**
- Cover
 - Castors
 - Perforated bowl
 - Capacity 3,7 litre/second
 - ø50 mm drain connection

